

Process Meter

K3MA-J-A2 AC100-240



Image

Process Meter, DC voltage/DC current input, Comparative output: 2 relay contact outputs (SPST-NO), Supply voltage: 100 to 240 VAC

Power supply voltage	100 to 240 VAC 50/60 Hz
Input type	DC voltage/DC current
Digits	5 digit (-19999 to 99999)

Ratings/Specifications

As of July 25, 2024

Power supply voltage		100 to 240 VAC 50/60 Hz
Allowable power supply voltage range		85 to 110% of the power supply voltage
Power consumption		6 VA max. (at maximum load)
Input type		DC voltage/DC current
Output type		Judgment output: Contact Comparative output: OUT1, OUT2
Current measurement input	Measurement range	0-20: 0 to 20 mA 4-20: 4 to 20 mA
	Indication range	0-20: -2.00 to 22.00 mA 4-20: 2.00 to 22.00 mA
	Accuracy	±0.1% FS ±1 digit max. (23±3 °C)
	Input impedance	Approx. 45 Ω
Voltage measurement input	Measurement range	0-5: 0 to 5 V 1-5: 1 to 5 V 5: ±5 V 10: ±10 V
	Indication range	0-5: -0.500 to 5.500 V 1-5: 0.500 to 5.500 V 5: ±5.500 V 10: ±11.000 V
	Accuracy	0-5: ±0.1% FS ±1 digit max. (23±3 °C) 1-5: ±0.1% FS ±1 digit max. (23±3 °C) 5: ±0.1% FS ±1 digit max. (23±5 °C) 10: ±0.1% FS ±1 digit max. (23±5 °C)
	Input impedance	1 MΩ min.

Judgment output	Contact output	2 output (SPST-NO) Rated load: Resistive load: 250 VAC 5 A (cosφ=1)/5 A at 30 VDC, Inductive load: 250 VAC 1 A (cosφ=0.4)/30 VDC 1 A (L/R=7 ms) Minimum applicable load: 10 mA at 5 VDC (failure level: P Reference value) Life expectancy: 100,000 operations min. (Electrical)/5,000,000 operations min. (Mechanical)
Display	Display method	Negative LCD (backlit LED) 7-segment digital display
	Digits	5 digit (-19999 to 99999)
	Character height	14.2 mm (green/red)
A/D conversion method		Double integral method
Sampling period		250 ms
Comparative output response time		750 ms max.
Insulation resistance		Between the entire external terminal and case: 20 MΩ min. (at 500 VDC) Between inputs, outputs, and power supply: 20 MΩ min. (at 500 VDC)
Dielectric strength		Between the entire external terminal and case: 2,000 VAC 1 min
Noise immunity		±1,500 V at power supply terminals in normal or common mode (waveform with 1-ns rising edge and pulse width of 1 μs/100 ns)
Vibration resistance		Malfunction: 10 to 55 Hz, Single amplitude 0.35 mm, 10 sweeps of 5 min each in X, Y, and Z directions
Shock resistance		Malfunction: 100 m/s ² , 3 times each in 3 axes 6 directions
Degree of protection		Front: NEMA TYPE 4X for indoor use (equivalent to IP66) Case rear: IP20 Terminals: IP00 + finger protection (VDE0106/100) with terminal Cover
Memory protection		Non-volatile memory (Number of rewrites: 100,000)
Ambient temperature		Operating: -10 to 55 °C (with no freezing or condensation) Storage: -25 to 65 °C (with no freezing or condensation)
Ambient humidity		Operating: 25 to 85 % (with no condensation)
Accessories		Waterproof packing, Terminal Cover, Unit label
Weight		Approx. 200 g

As of July 25, 2024

Dimensions

As of July 25, 2024

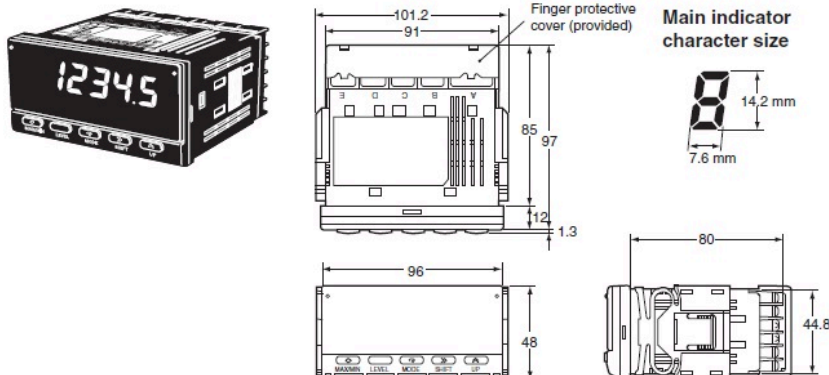

Panel cut-out

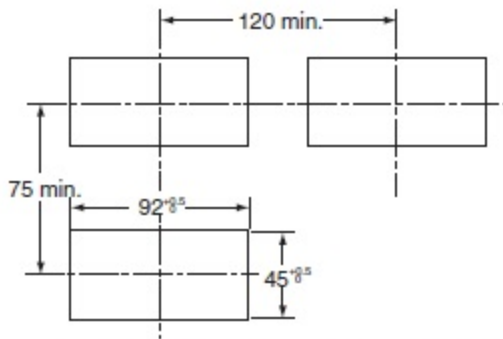

Mounting Recommended Panel Thickness
1 to 8 mm.
Mount the product horizontally.

As of July 25, 2024

Connection diagram

As of July 25, 2024

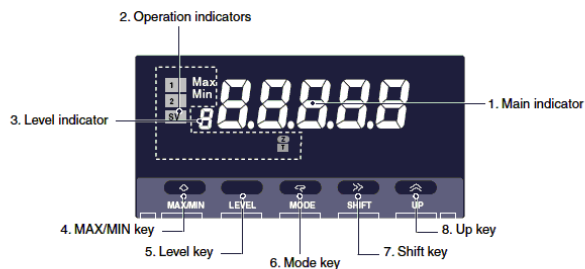

Name	Functions
1. Main indicator	Displays current values, parameters, and set values.
2. Operation indicators	1 Lit when output 1 is ON.
	2 Lit when output 2 is ON.
	SV Lit when a set value is being displayed or changed.
	Max Lit when the main indicator is showing the MAX value.
	Min Lit when the main indicator is showing the MIN value.
	Z Lit during the forced-zero operation.
T Lit when the teaching function is operable. Blinks while the teaching function is operating.	
3. Level indicator	Displays the current level that the K3MA-J is in. (See below for details.)
4. MAX/MIN Key	Used to display the MAX and MIN values when a measurement value is being displayed.
5. Level Key	Used to change the level.
6. Mode Key	Used to allow the main indicator to indicate parameters sequentially.
7. Shift Key	Used to enable a set value to be changed. When changing a set value, this key is used to move along the digits.
8. Up Key	Used to change a set value. Used to set or clear a forced-zero function when a measurement value is being displayed.

Level indicator	Level
p	Protect
Not lit	Operation
s	Initial setting
f	Advanced-function setting

Terminal arrangement

Terminal Arrangement

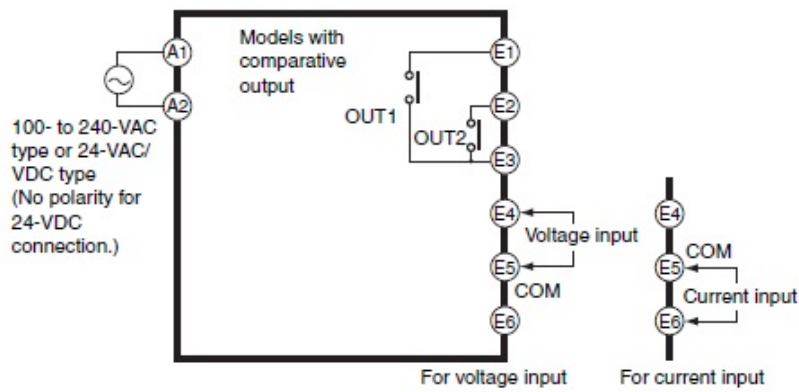
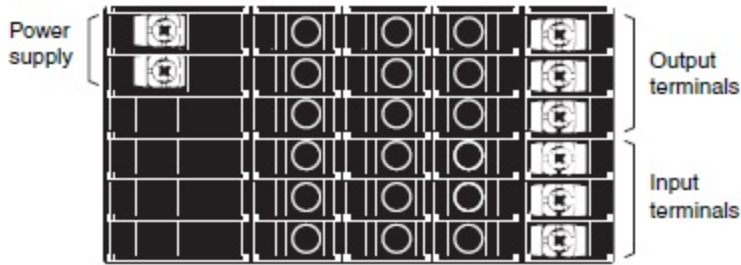

As of July 25, 2024

Internal connection

As of July 25, 2024

Block Diagram

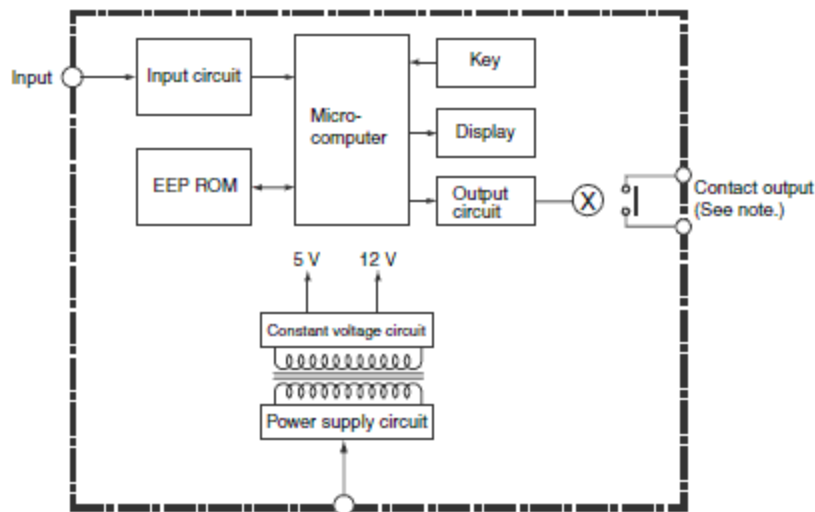

Note: Relay output models only.

